

Features

- **Supports all variants of SXGA120-R5 OLED**
 - BIT1013A1: EMA-101400-01 - Color XL
 - BIT1013A2: EMA-101462-01 - Monochrome Green XLT
- **Low Power: < 1W (less OLED)**
- **Digital RGB Video Interface**
DVI, HDMI (no HDCP): 24bRGB
- **Monocular: 1 OLED Channel**
- **Supported Video Timing Formats**
VGA, SVGA, XGA, SXGA, HD (720p)
- **User-selectable Control Options**
USB, UART, Discrete
- **Continuous Image Optimization**
- **Mechanically Centered OLED Image**
- **Power Enable / Disable Feature**
Rapid start-up
Ultra-Low-power disable
- **User-configurable Mounting Features (Tabs)**
- **Industrial Temperature Range (-40~70C)**

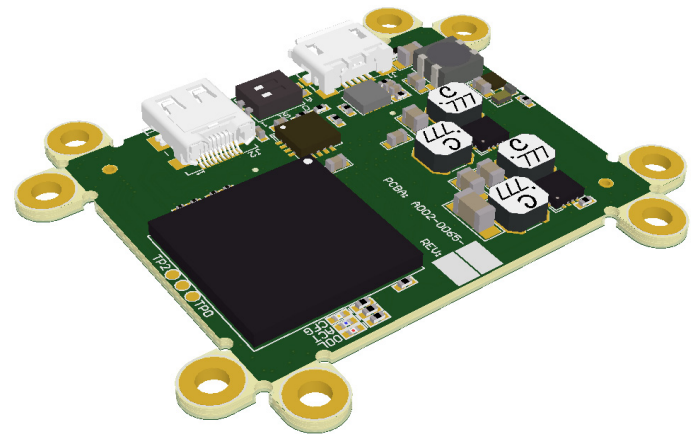
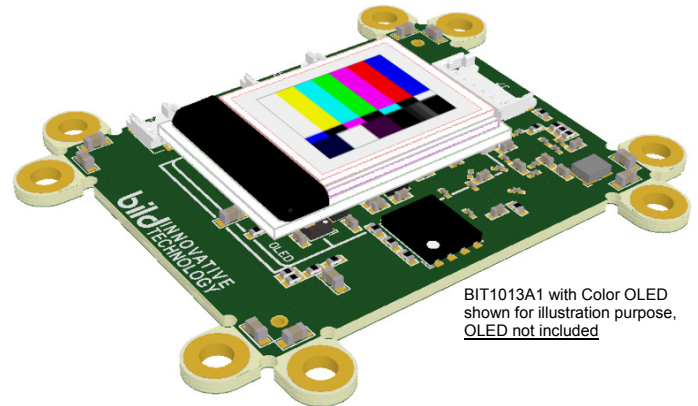

Applications

- **Head Mounted Displays (HMD)**
- **Wearable Devices**
- **Virtual / Augmented Reality**
- **Embedded Viewers**
- **Electronic Viewfinder**
- **Instrumentation**
- **Hobby**

General Description

The BIT1013A is a high-performance low-cost full-featured driver supporting the Color eMagin DSVGA OLED. Integrated dual-mode DVI / HDMI digital video input and multiple control interface options enable a compact single-board design suitable for virtually any application including binocular HMDs for users with narrow interpupillary distance (IPD).

Product Highlights

Lightweight low-profile compact design is optimized for both monocular and binocular display devices for both direct-view and reflective eyepiece designs. Symmetrical layout placing the OLED image centroid in the exact center of the Driver supports easy monocular left/right eye switching as well as binocular side-by side mounting. Image position and orientation controls facilitate rotation and binocular convergence adjustments / fine-tuning.

With all connectors located on a common edge directly supports plenum style end-product wire harnessing. This is especially helpful for routing wires along the upper edge of a binocular display assembly to minimize look-down obscuration of the mechanical structure.

Eight configurable #2 mounting tabs strategically arranged in 90-degree pairs at each corner provide a flexible easily customizable attachment system suitable for a variety of mechanical configurations. Unused mounting tabs can be simply snapped off and discarded.

The user selectable control interface supports easy adaptation to the most popular serial and discrete control interfaces. The 3.3V UART control option features a unique chip-select allowing multiple OLED drivers to be controlled by a common Tx/Rx pair, a unique feature intended specifically for binocular configurations. Combining the BIT1013A OLED Driver with the BIT1100A discrete control module yields a complete standalone monocular display driver solution with convenient 3-button user controls.

Low operational power plus reduced-power standby and ultra-low-power disable modes provide flexible power control necessary to ensure long battery life for today's and future portable devices.

Additional features such as programmable brightness control steps, maximum brightness, built-in test patterns, user selectable gamma, video inversion, and video format query give the user all the necessary degrees of control to customize and diagnose the end-product – these user control features are unique to Bild's OLED Drivers.

Technical Specifications

Parameter		min	typ	max	unit
Supply Voltage	J4 Power Connector	2.5	5.0	5.5	V
	USB Connector	4.75	5.0	5.25	V
Power Consumption (less OLED)	Operating	-	600	1000	mW
	Reduced-Power Standby (input video active)		400		mW
	Power Disabled		1		mW
Video	Input Type 1: DVI	1.0			
	Input Type 2: HDMI - HDCP not supported	1.3a			
	Color Depth	24b RGB			
	Frame Resolution, typ	See Input Video			
	Frame Rate, typ				
Control Interface	Option 1: USB (UART protocol)	USB 2.0, 115.2kbps			
	Option 2: UART	3.3V, 115.2kbps			
	Option 3: Discrete	2-wire, integrated pullups			
Temperature (ambient)	Operating Industrial	-40	-	70	°C
	Storage	-40	-	85	°C
Mass		7			g

Absolute Maximum Ratings

Stresses above those listed under Absolute Maximum Ratings may cause permanent damage to the device. This is a stress rating only; the functional operation of the device at these or any other conditions above those indicated in the operational sections of this specification is not implied. Exposure to absolute maximum rating conditions for extended periods may affect device reliability.

Notes: 1) Reverse-polarity protection

Parameter		min	max	unit	Note
Supply Voltage	J1 USB Connector	-0.3	6.0	V	1
	J4 Power Connector	-6.0	6.0	V	
Digital IO	J1 USB: DN, DP	-0.5	3.63	V	
	J2 TMD5	-0.4	3.85	V	
	J2 DDC: SCL, SDA	-0.5	7.0	V	
	J5 (pins 1~3)	-0.4	3.85	V	
Temperature (ambient)		-40	85	°C	

ESD Caution

ESD (electrostatic discharge) sensitive device. Electrostatic charges as high as 4000 V readily accumulate on the human body and test equipment and can discharge without detection. Although this product features ESD protection circuitry, permanent damage may occur on devices subjected to high energy electrostatic discharges. Therefore, proper ESD precautions are recommended to avoid performance degradation or loss of functionality.



Package Outline

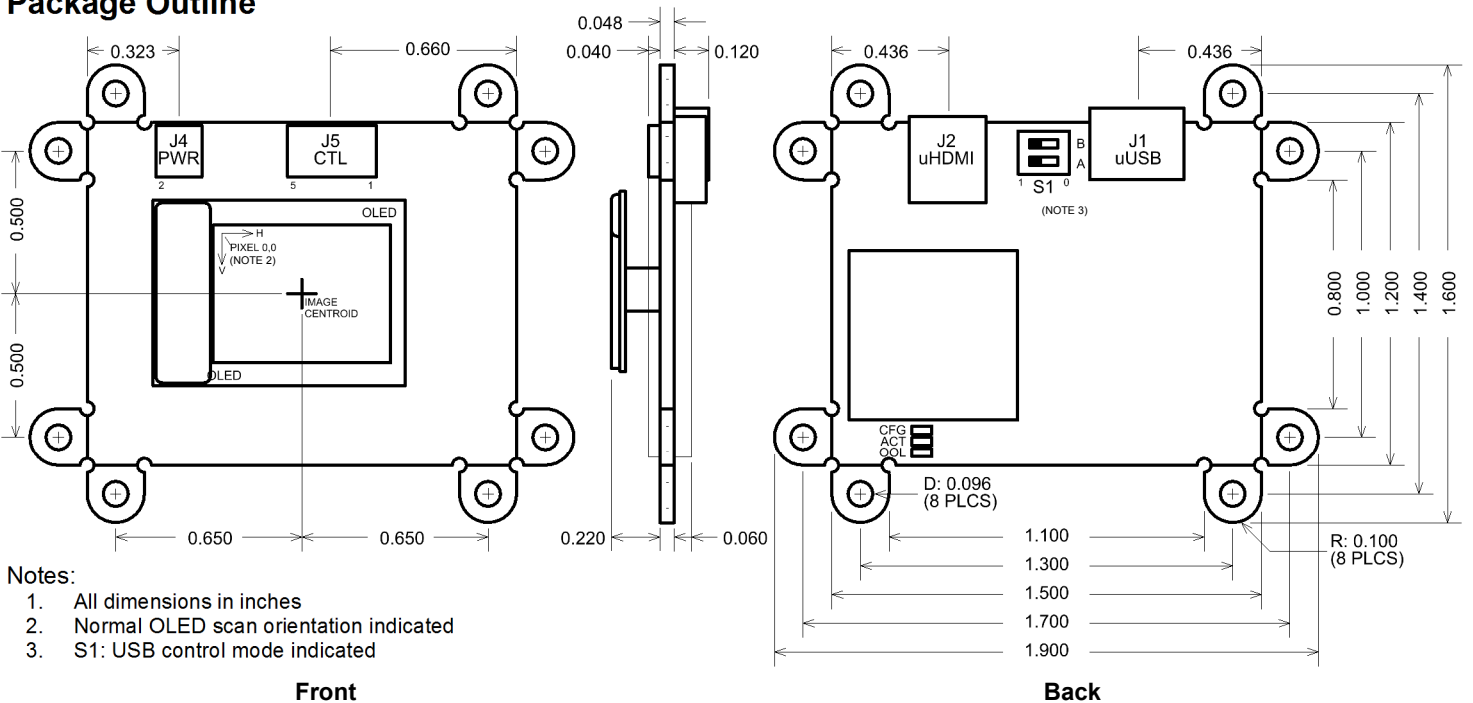

Connectors

J1: USB

Type: micro USB Type B
Pinout:

Pin #	Function
1	+5V / Supply Power
2	USB_DN
3	USB_DP
4	nc
5	GND

J2: uHDMI

Type: micro HDMI Type D
Pinout:

Pin #	Function
1	HPD
2	nc
3	TMDS_D2+
4	GND
5	TMDS_D2-
6	TMDS_D1+
7	GND
8	TMDS_D1-
9	TMDS_D0+
10	GND
11	TMDS_D0-
12	TMDS_CK+
13	GND
14	TMDS_CK-
15	nc
16	GND
17	DDC_SCL
18	DDC_SDA
19	+5V

J4: Power

Manufacturer: Molex
Manufacturer PN: 78171-0002
Mating PN: 78172-0002
Pinout:

Pin #	Function
1	Supply Power
2	GND

J5: Control

Manufacturer: Molex
Manufacturer PN: 78171-0005
Mating PN: 78172-0005
Pinout:

Pin #	Function (by S1 A B Control Setting)			Pull-up/down
	0 0 Discrete	1 0 UART	1 1 USB	
1	PD1	TX	n/a	50kOhm pullup to 3.3V
2	PD2	RX	n/a	50kOhm pullup to 3.3V
3	n/a	CSn	n/a	10kOhm pulldown to GND
4	PWR_EN			10kOhm pullup to supply voltage
5	GND			n/a

Operation

Supply Power

The BIT1013A supports application of supply power via either the micro USB connector or dedicated Supply Power connector J4. The dedicated J4 Supply Power path provides reverse polarity protection whereas the USB supply power path does not. Automatic input supply power selection is performed according to the following table:

USB Pwr	J4 Pwr	Selected Supply Power
No	Yes	J4 Power
Yes	No	USB Power
Yes	Yes	J4 Power

Setting serial command **POWER** to **0** places the BIT1013A in a reduced power state in which all video functions are disabled but serial communications remain active. Restoring serial command **POWER** to **1** returns the BIT1013A to a fully operational state.

Deasserting J5 pin 4 (PWR_EN) to logic low places the BIT1013A into an extremely low power state in which serial communication is disabled. Reasserting PWR_EN to logic high will cause a re-start of the BIT1013A.

Status Indicator LEDs

The BIT1013A1 features three (3) status indicator LEDs as follows:

Label	Color	Status Function
CFG	Amber	ON Configuration incomplete / in progress
		OFF Configuration complete
ACT	Blue	Luminance modulation indicates processor activity
OOL	Red	ON HDMI / DVI clock not locked
		OFF HDMI / DVI clock locked

Status LED locations shown below:

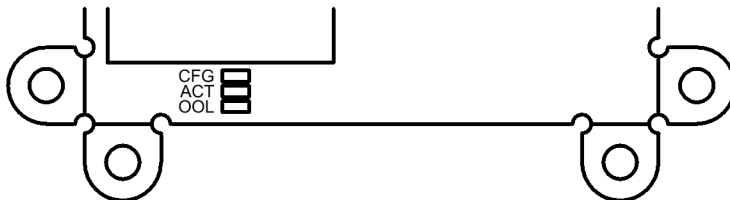

ACT and OOL Status LEDs can be disabled via the **LEDEN** serial command (ref: BIT-UG-0006).

Input Video

The BIT1013A supports both HDMI 1.3a and DVI 1.0 formats at 24 bit RGB. EDID specifies the following timing formats:

VGA (640x480) - displayed as 1280X960:

Parameter	VESA Standard			
	640x480_60	640x480_72	640x480_75	640x480_85
FP Pixel Clock Frequency	25.175 MHz	31.500 MHz	31.500 MHz	36.000 MHz
FH Horizontal Frequency	31.469 kHz	37.861 kHz	37.500 kHz	43.269 kHz
FV Vertical Frequency	59.940 Hz	72.809 Hz	75.000 Hz	85.008 Hz
HS Horizontal Sync	96 col : 3.813 us	40 col : 1.270 us	64 col : 2.032 us	56 col : 1.556 us
HB Horizontal Backporch	48 col : 1.907 us	128 col : 4.063 us	120 col : 3.810 us	80 col : 2.222 us
HA Horizontal Active	640 col : 25.422 us	640 col : 20.317 us	640 col : 20.317 us	640 col : 17.778 us
HF Horizontal Frontporch	16 col : 0.636 us	24 col : 0.762 us	16 col : 0.508 us	56 col : 1.556 us
HT Horizontal Total	800 col : 31.778 us	832 col : 26.413 us	840 col : 26.667 us	832 col : 23.111 us
VS Vertical Sync	2 row : 63.555 us	3 row : 79.238 us	3 row : 80.000 ms	3 row : 69.333 us
VB Vertical Backporch	33 row : 1.049 ms	28 row : 0.740 ms	16 row : 0.427 ms	25 row : 0.578 ms
VA Vertical Active	480 row : 15.253 ms	480 row : 12.678 ms	480 row : 12.800 ms	480 row : 11.093 ms
VF Vertical Frontporch	10 row : 0.318 ms	9 row : 0.238 ms	1 row : 26.667 us	1 row : 23.111 us
VT Vertical Total	525 row : 16.683 ms	520 row : 13.735 ms	500 row : 13.333 ms	509 row : 11.764 ms

SVGA (800x600):

Parameter	VESA Standard				
	800x600_56	800x600_60	800x600_72	800x600_75	800x600_85
FP Pixel Clock Frequency	36.000 MHz	40.000 MHz	50.000 MHz	49.500 MHz	56.250 MHz
FH Horizontal Frequency	35.156 kHz	37.879 kHz	48.077 kHz	46.875 kHz	53.674 kHz
FV Vertical Frequency	56.250 Hz	60.317 Hz	72.188 Hz	75.000 Hz	85.061 Hz
HS Horizontal Sync	7 col : 2.000 us	128 col : 3.200 us	120 col : 2.400 us	80 col : 1.616 us	64 col : 1.138 us
HB Horizontal Backporch	128 col : 3.556 us	88 col : 2.200 us	64 col : 1.280 us	160 col : 3.232 us	152 col : 2.702 us
HA Horizontal Active	800 col : 22.222 us	800 col : 20.000 us	800 col : 16.000 us	800 col : 16.162 us	800 col : 14.222 us
HF Horizontal Frontporch	24 col : 0.667 us	40 col : 1.000 us	56 col : 1.120 us	16 col : 0.323 us	32 col : 0.569 us
HT Horizontal Total	1024 col : 28.444 us	1056 col : 26.400 us	1040 col : 20.800 us	1056 col : 21.333 us	1048 col : 18.631 us
VS Vertical Sync	2 row : 56.889 us	4 row : 0.106 ms	6 row : 0.125 ms	3 row : 64.000 us	3 row : 55.893 us
VB Vertical Backporch	22 row : 0.626 ms	23 row : 0.607 ms	23 row : 0.478 ms	21 row : 0.448 ms	27 row : 0.503 ms
VA Vertical Active	600 row : 17.067 ms	600 row : 15.840 ms	600 row : 12.480 ms	600 row : 12.800 ms	600 row : 11.179 ms
VF Vertical Frontporch	1 row : 28.444 us	1 row : 26.400 us	37 row : 0.770 us	1 row : 21.333 us	1 row : 18.631 us
VT Vertical Total	625 row : 17.778 ms	628 row : 16.579 ms	666 row : 13.853 ms	625 row : 13.333 ms	631 row : 11.756 ms

XGA (1024x768):

Parameter	VESA Standard			
	1024x768_60	1024x768_70	1024x768_75	1024x768_85
FP Pixel Clock Frequency	65.000 MHz	75.000 MHz	78.750 MHz	94.500 MHz
FH Horizontal Frequency	48.363 kHz	56.476 kHz	60.023 kHz	68.677 kHz
FV Vertical Frequency	60.004 Hz	70.069 Hz	75.029 Hz	84.997 Hz
HS Horizontal Sync	136 col : 2.092 us	136 col : 1.813 us	96 col : 1.219 us	96 col : 1.016 us
HB Horizontal Backporch	160 col : 2.462 us	144 col : 1.920 us	176 col : 2.235 us	208 col : 2.201 us
HA Horizontal Active	1024 col : 15.754 us	1024 col : 13.653 us	1024 col : 13.003 us	1024 col : 10.836 us
HF Horizontal Frontporch	24 col : 0.369 us	24 col : 0.320 us	16 col : 0.203 us	48 col : 0.508 us
HT Horizontal Total	1344 col : 20.677 us	1328 col : 17.707 us	1312 col : 16.660 us	1376 col : 14.561 us
VS Vertical Sync	6 row : 0.124 ms	6 row : 0.106 ms	3 row : 49.981 us	3 row : 43.683 us
VB Vertical Backporch	29 row : 0.600 ms	29 row : 0.513 ms	28 row : 0.466 ms	36 row : 0.524 ms
VA Vertical Active	768 row : 15.880 ms	768 row : 13.599 ms	768 row : 12.795 ms	768 row : 11.183 ms
VF Vertical Frontporch	3 row : 62.031 us	3 row : 53.120 us	1 row : 16.660 us	1 row : 14.561 us
VT Vertical Total	806 row : 16.666 ms	806 row : 14.272 ms	800 row : 13.328 ms	808 row : 11.765 ms

SXGA (1280x1024):

Parameter	VESA Standard		Reduced Blanking (RB)	
	1280x1024_60	1280x1024_60(RB)	1280x1024_75(RB)	1280x1024_85(RB)
FP Pixel Clock Frequency	108.00 MHz	81.187 MHz	101.484 MHz	115.010 MHz
FH Horizontal Frequency	63.981 kHz	61.880 kHz	77.350 kHz	87.660 kHz
FV Vertical Frequency	60.020 Hz	60.020 Hz	75.025 Hz	85.024 Hz
HS Horizontal Sync	112 col : 1.037 us	8 col : 0.099 us	8 col : 0.079 us	8 col : 0.070 us
HB Horizontal Backporch	248 col : 2.296 us	12 col : 0.148 us	12 col : 0.118 us	12 col : 0.104 us
HA Horizontal Active	1280 col : 11.852 us	1280 col : 15.766 us	1280 col : 12.613 us	1280 col : 11.129 us
HF Horizontal Frontporch	48 col : 0.444 us	12 col : 0.148 us	12 col : 0.118 us	12 col : 0.104 us
HT Horizontal Total	1688 col : 15.630 us	1312 col : 16.160 us	1312 col : 12.928 us	1312 col : 11.408 us
VS Vertical Sync	3 row : 46.889 us	2 row : 32.320 us	2 row : 25.856 us	2 row : 22.815 us
VB Vertical Backporch	38 row : 0.594 ms	3 row : 48.481 ms	3 row : 38.785 ms	3 row : 34.223 ms
VA Vertical Active	1024 row : 16.005 ms	1024 row : 16.548 ms	1024 row : 13.238 ms	1024 row : 11.682 ms
VF Vertical Frontporch	1 row : 15.630 us	2 row : 32.320 us	2 row : 25.856 us	2 row : 22.815 us
VT Vertical Total	1066 row : 16.661 ms	1031 row : 16.661 ms	1031 row : 13.329 ms	1031 row : 11.761 ms

HD:

Standard
720p / 60Hz

Image Orientation

Image orientation is adjustable via discrete and serial control according to the following table.
 ref: BIT-UG-0006: User Guide, OLED Driver UART Protocol

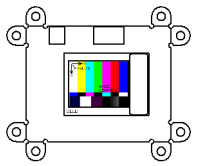
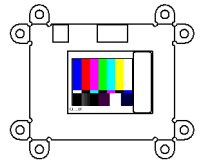
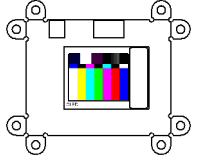
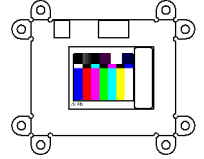
HSCAN	VSCAN	Image Orientation	HSCAN	VSCAN	Image Orientation
0	0		1	0	
0	1		1	1	

Control Interface – Channel Selection

The BIT1013A is controlled via one of several user-selectable interfaces according to the following table:

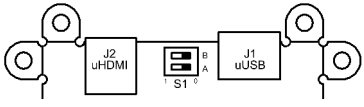
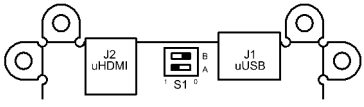
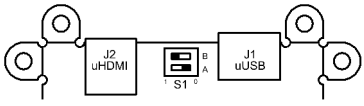
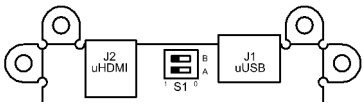
A B	S1 Switch Position Physical	Selected Control Interface
1 1		USB (Factory Default)
0 1		UART
1 0		<i>Reserved</i>
0 0		Discrete

Control Interface - Serial

USB and UART serial control interface, protocol, and commands are described by the following documents:

- BIT-UG-0000** User Guide, UART Protocol, General
- BIT-UG-0006** User Guide, UART Protocol, OLED Driver

USB serial interface implements an FTDI FT234XD-R UART transceiver.

Control Interface - Discrete

Discrete control is implemented via a 2-wire logic interface whereby control action is initiated by driving one or both inputs to GND (logic low). These inputs can be driven by active digital logic or simple pull-down as by a normally-open switch. The control action is defined by the table below. All control actions are executed upon release (return to logic high) – no sustained assertion actions are supported.

PD1	PD2	Control Action
1	1	No operation
0	1	Brightness Increment
1	0	Brightness Decrement
0	0	Image Orientation Flip

The Image Orientation Flip control action performs sequential alternating horizontal and vertical scan reversals (flips) upon successive assertions as follows:

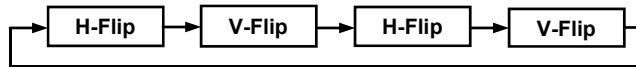

Brightness Control

BIT1013A brightness is adjusted in perceptually linearized discrete steps defined by control parameters **BRT**, **BRTMOD**, and **MAXLUM** (ref: BIT-UG-0006) as illustrated below (normalized luminance scale).

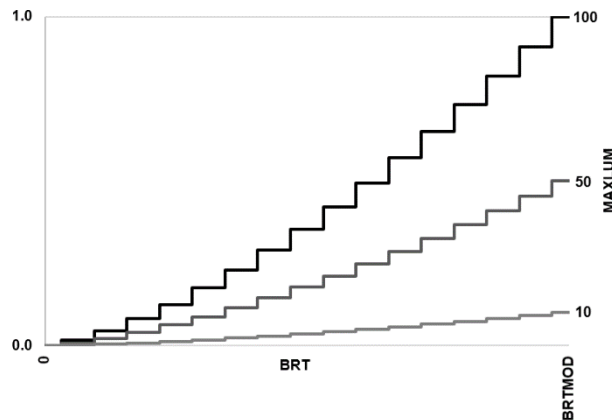

Serial control supports direct arbitrary control of the **BRT**, **BRTMOD**, and **MAXLUM** brightness control parameters.

Discrete control supports single-step increment and decrement of the **BRT** parameter.

Gamma Control

BIT1013A gamma is adjusted by the **GAMMA** (ref: BIT-UG-0006) command which applies a standard normalized exponential transfer function ($\text{PixelValue}^{\text{GAMMA}}$) to emulate CRT phosphor characteristics as shown below.

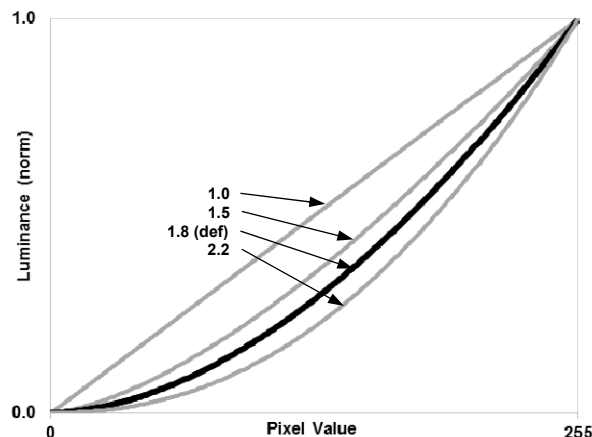

Mounting Tabs

The BIT1013A features eight (8) configurable EMI mounting tabs. These through-plated mounting tabs are located in pairs at the corners of the OLED Driver and provide high-frequency AC coupling to GND. To accommodate a variety of mechanical mounting configurations, these tabs can be removed as needed from the OLED Driver by breaking away at the pre-cut v-groove break lines. Care must be taken to prevent damage to the OLED Driver.

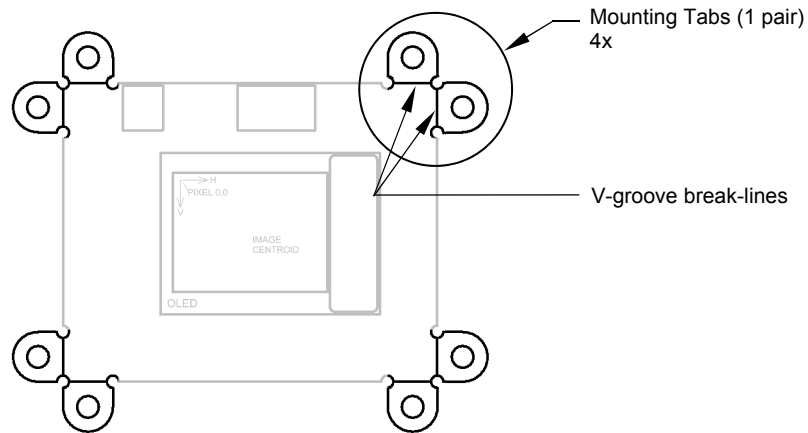

Orderable Part Numbers

Base PN: BIT1013A BIT1013A1

- 1: Pre-configured – Color OLED
- 2: Pre-configured – Monochrome Green OLED

Contact

Bild Innovative Technology LLC
2656 W Montrose Ave Suite 203
Chicago, IL 60618
(773) 697-9345
(760) 450-6633

<https://www.bildinnotech.com/contact>

Revision History

Rev	Date	Description
A	05/24/21	Initial Release